



STANFORD RESEARCH SYSTEMS

SR844 RF Lock-In Amplifier

25 kHz - 200 MHz



SR844 Dual Phase RF Lock-In Amplifier

- 25 kHz to 200 MHz frequency range
- DSP technology for high dynamic reserve, excellent gain stability and zero drift
- Time constants from 100 μ s to 30 ks (6, 12, 18, 24 dB/oct rolloff)
- No output filter mode (10 to 20 μ s update rate)
- Auto gain, phase, reserve and offset
- Reference output
- Two 16-bit ADCs and DACs
- GPIB and RS-232 interfaces

Presenting the SR844 Dual Phase, RF Lock-In Amplifier. Unlike simple down-converters, *no* additional instruments are required, and unlike analog lock-ins, *no* manual frequency range switching is necessary.

The SR844 provides uncompromised performance with a frequency range of 25 kHz to 200 MHz and up to 80 dB of drift-free dynamic reserve. And of course, the SR844 includes the many features, ease of operation, and programmability that you've come to expect from SRS DSP lock-in amplifiers. If your application involves high frequency signal detection, there's no better choice than the SR844.

Digital Technology

The SR844 uses the same advanced DSP technology found in the SR850, SR830 and SR810 lock-in amplifiers. DSP offers many advantages over analog instruments - high dynamic reserve, zero drift, accurate RF phase shifts and orthogonality, and digital output filtering.

Most important of all, digital technology delivers optimum performance at a price that's thousands less than other RF lock-in solutions.

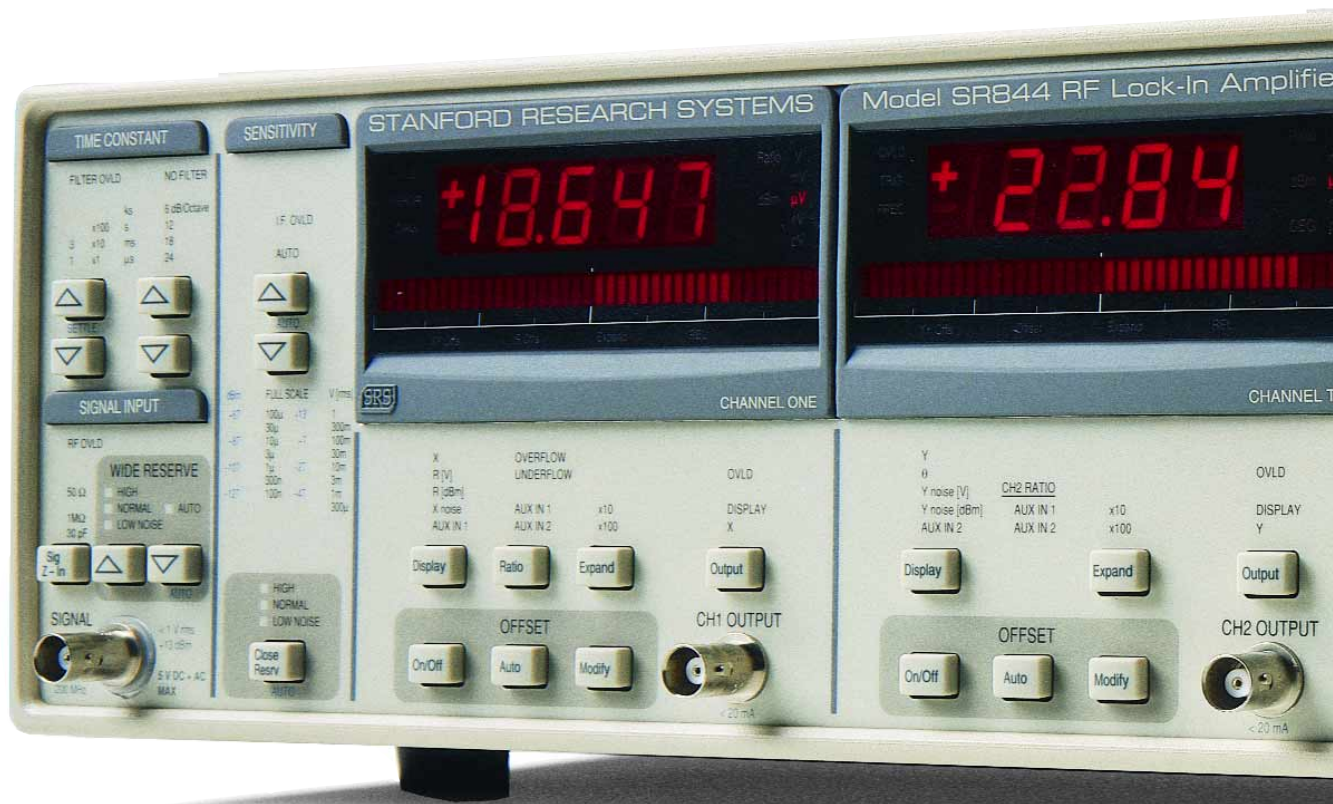

Signal Input

The SR844 has both 50 Ω and 1 M Ω inputs. The 1 M Ω input is used with high source impedances at low frequencies, or with a standard 10X scope probe. The 50 Ω input provides the best RF signal matching. Full scale sensitivities range from 1V down to 100 nV. Three wideband dynamic reserve selections are available.

Reference

The SR844 offers both external and internal reference operation. In both cases, the entire 25 kHz to 200 MHz frequency range is covered without any manual range selection. The external reference input has an auto-threshold feature which locks to sine, TTL, or NIM signals. The internal reference is digitally synthesized and is adjustable with 3 digit frequency resolution.

Harmonic detection of the 2F component is available for both internal and external reference modes.

A reference output (1.0 Vpp square wave into 50 Ω) which is phase synchronous with the lock-in reference is available in both external and internal mode.

Output Filters

Time constants from 100 μ s to 30 ks can be selected, with the choice of 6, 12, 18 or 24 dB/oct rolloff. For high bandwidth, real-time outputs, the filtering can be by-passed entirely. In this No Filter mode, the effective time constant is about 30 μ s with the analog outputs updating every 10 to 20 μ s.

Ease of Operation

Unlike other RF lock-in amplifiers, the SR844 is easy to use. All instrument functions are set from the

front panel keypad, and the knob is used to quickly adjust parameters. Up to nine different instrument configurations can be stored in non-volatile memory for fast, reliable instrument setup. Standard RS-232 and GPIB (IEEE-488.2) interfaces provide connections to your data acquisition systems.

Useful Features

Auto-functions allow parameters that are frequently adjusted to be set automatically. Sensitivity, dynamic reserve, phase and offset are each quickly optimized with a simple key stroke.

The offset and expand features are useful for evaluating small fluctuations in your signal. The input is nulled with the auto-offset function and output expand increases the resolution by up to 100 times.



Ratio mode is used to normalize the signal to an externally applied analog voltage. It is useful to eliminate the effect of source intensity fluctuations.

Transfer function measurements can be easily made from the front panel by a programmable scan of up to 11 frequencies. Setups and offsets are recalled at each frequency in the scan.

Analog Inputs and Outputs

The two displays each have a user-defined output for measuring X, Y, R, R(dBm), θ , and Xnoise or Y noise. Two user programmable DACs provide -10.5 V to +10.5 V voltages with 1 mV resolution. These outputs may be set from the front panel or via the computer interfaces.

In addition, there are two general purpose analog inputs. These are 16-bit ADCs which can be displayed on the front panel, read over the interface, or used to ratio the input signal.

Internal Memory

The SR844 has two 16,000 point memory buffers for recording the time history of each measurement display at rates up to 512 samples/sec. Data may be transferred from the buffers using either interface. A trigger input is also provided to synchronize data

recording with external events.

Outstanding Value

The SR844 RF Lock-In Amplifier from Stanford Research Systems represents a true breakthrough in high frequency lock-in amplifier design. Performance, features, and value – nothing else compares with the SR844.



Specifications

Signal Channel

Voltage input	single-ended BNC
Input impedance	50 Ω or 1 M Ω + 30 pF
Damage Threshold	± 5 V (DC+AC)
Bandwidth	25 kHz to 200 MHz
Sensitivity:	
< 1 MHz	100 nVrms to 1 Vrms full scale (-127 dBm to +13 dBm full scale)
< 50 MHz	1 μ Vrms to 1 Vrms full scale
< 200 MHz	10 μ Vrms to 1 Vrms full scale
Gain accuracy:	
< 50 MHz	± 0.25 dB
< 200 MHz	± 0.50 dB
Gain Stability	0.2% / $^{\circ}$ C
Coherent Pickup	Low Noise Reserve, Sens. < 30 mV
f < 10 MHz	< 100 nV (typical)
f < 100 MHz	< 1.0 μ V (typical)
f < 200 MHz	< 2.5 μ V (typical)
Input noise: 50 Ω Input	
100 kHz < f < 100 MHz	2 nV/ $\sqrt{\text{Hz}}$ (typ.), 4 nV/ $\sqrt{\text{Hz}}$ (max.)
25 kHz < f < 200 MHz	< 5 nV/ $\sqrt{\text{Hz}}$ (typ.), < 8 nV/ $\sqrt{\text{Hz}}$ (max.)
Input noise: 1 M Ω Input	
25 kHz < f < 200 MHz	5 nV/ $\sqrt{\text{Hz}}$ (typ.), < 8 nV/ $\sqrt{\text{Hz}}$ (max.)
Dynamic reserve	up to 80 dB

Reference

External Reference Input	25 kHz to 200 MHz
Impedance	50 Ω or 10 k Ω + 40 pF
Level	0.7 Vpp pulse or 0 dBm sine
Pulse Width	> 2ns at any frequency
Threshold Setting	Automatic, midpoint of waveform
Acquisition Time	< 10s (auto-ranging, any frequency) < 1s (within same octave)
Internal Reference	25 kHz to 200 MHz
Frequency Resolution	3 digits
Frequency Accuracy	± 0.1 in the 3rd digit
Harmonic Detection	2F (signal from 50 kHz to 200 MHz)
Reference Outputs	Phase locked to Int. or Ext. reference
Front Panel Ref Out	25 kHz to 200 MHz square wave 1.0 Vpp nominal into 50 Ω
Rear Panel TTL Out	25 kHz to 1.5 MHz, 0 to +5 V nominal, ≥ 3 V into 50 Ω
Phase Resolution	0.02 $^{\circ}$
Absolute Phase Error:	
< 50 MHz	< 2.5 $^{\circ}$
< 100 MHz	< 5.0 $^{\circ}$
< 200 MHz	< 10.0 $^{\circ}$
Rel. Phase Error, Orthog.	< 2.5 $^{\circ}$
Phase Noise (external)	0.005 $^{\circ}$ rms at 100 MHz, 100 ms TC
Phase Drift	
< 10 MHz	< 0.1 $^{\circ}$ / $^{\circ}$ C
< 100 MHz	< 0.25 $^{\circ}$ / $^{\circ}$ C
< 200 MHz	< 0.5 $^{\circ}$ / $^{\circ}$ C

Demodulator

Zero Stability	Digital displays have no zero drift. Analog outputs have < 5 ppm/ $^{\circ}$ C drift for all dynamic reserve settings.
Filtering	
Time Constants	100 μ s to 30 ks with 6, 12, 18 or 24 dB/octave roll-off
No Filter	10-20 μ s update rate (X and Y outputs)

Harmonic Rejection	
Odd Harmonics	-9.5 dBc @3xRef, -14 dBc @ 5xRef, etc. (20log 1/n where n = 3, 5, 7, 9...)
Other Harmonics and sub-harmonics	< -40 dBc
Spurious Responses	-10 dBc @Ref ± 2 x IF -23 dBc @Ref ± 4 x IF < -30 dBc otherwise. (2 kHz < IF < 12 kHz)

Displays

Channel 1:	
Type	4.5 digit LED with 40 seg. bar graph
Quantities	X,R[V], R[dBm], Xnoise, AuxIn 1
Channel 2:	
Type	4.5 digit LED with 40 seg. bar graph
Quantities	Y, θ [deg], Ynoise[V], Ynoise[dBm], AuxIn 2
Expand	x10 or x100 for Ch1, Ch2 displays and outputs
Ratio	X and Y ratioed with respect to AuxIn 1 or AuxIn 2 before filtering and computation of R. The ratio input is normalized to 1 V and has a dynamic range greater than 100.
Reference:	
Type	4.5 digit LED
Quantities	Ref Freq, Phase, Offsets, AuxOut, IF Freq, Elapsed Time

Channel 1 and Channel 2 Outputs

Voltage Range	± 10 V full scale proportional to X, Y or CH1, CH2 displayed quantity
Update Rate:	
X, Y	≥ 48 kHz
R, θ , Aux Inputs	≥ 10 kHz
X noise, Ynoise	512 Hz

Auxiliary Inputs and Outputs

Inputs	2
Type	Differential, 1 M Ω
Range	± 10 V
Resolution	1/3 mV
Bandwidth	3 kHz
Outputs	2
Range	± 10 V
Resolution	1 mV
Data Buffers	Two 16,000 point buffers. Data is recorded at rates up to 512 Hz and is read using the computer interfaces.

General

Interfaces	IEEE-488 and RS-232 interfaces are standard. All instrument functions can be controlled and read through the interfaces.
Power	70 Watts, 100/120/220/240 VAC, 50/60 Hz.
Dimensions	17" W x 5.25" H x 19.5" D
Weight	23 lbs.
Warranty	One year parts and labor on materials and workmanship

Inside the SR844

At the RF operating frequencies of the SR844, analog mixers must be used to mix the reference with the signal. However, these analog mixers, while providing excellent RF performance, suffer from serious DC output errors. In a lock-in amplifier, the desired output from the mixer is often much smaller than these DC errors. In an analog lock-in, large RF gains are necessary to overcome this problem, at the expense of accuracy and dynamic reserve. The SR844 solves this problem by 'chopping', or mixing, the reference signal with a lower intermediate frequency (IF). When this chopped reference is mixed with the signal, the desired mixer output is at

the IF frequency, not at DC. This entirely avoids the DC problem associated with the mixers. The final conversion from the IF is performed digitally using SRS's DSP lock-in technology. The most important benefits of this architecture are lower RF gain resulting in higher accuracy and dynamic reserve, and precise phase shifting. In addition, DSP processing provides digital output filtering, fast computation of magnitude and phase, signal ratio measurement, and many other features. The SR844 combines the best analog and digital techniques, resulting in state-of-the-art performance at an affordable price.

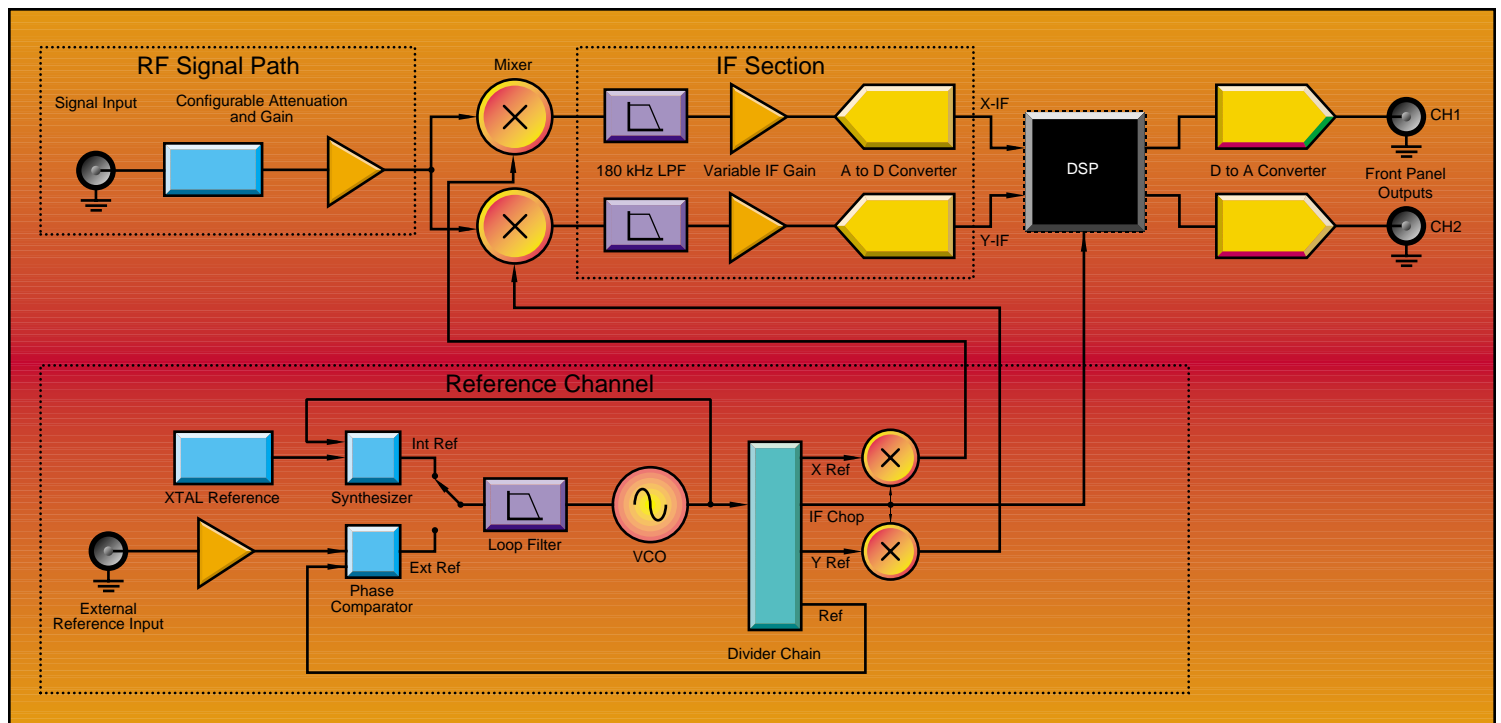

Ordering Information

SR844

RF Lock-In Amplifier

(includes rackmount hardware)



STANFORD RESEARCH SYSTEMS

1290-D Reamwood Avenue • Sunnyvale, CA 94089

Telephone: (408)744-9040 • FAX: (408)744-9049

email: info@thinkSRS.com

WWW: www.thinkSRS.com